

MODEL RC*

WT. = 23 LBS. WITHOUT LEVER

TEMP. = -30°F TO +160°F

Wingshaft has 48 serrations.

Lever can be mounted in any position indicated to suit individual installation.

UR-1 represents one serration up, lever to the right. DL-1 represents one serration down, lever to the left in relation to centerline of the wingshaft.

Positions shown indicate centers of travel. One serration equals 7-1/2°.

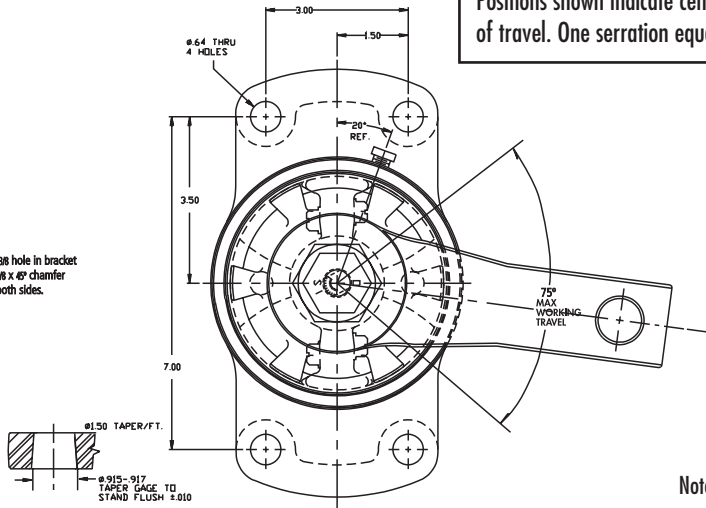
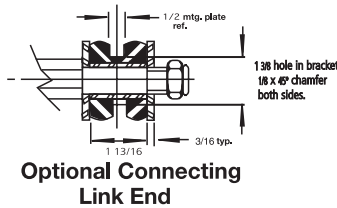
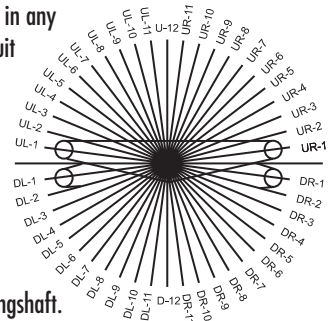

Note: All Dimensions are in Inches.

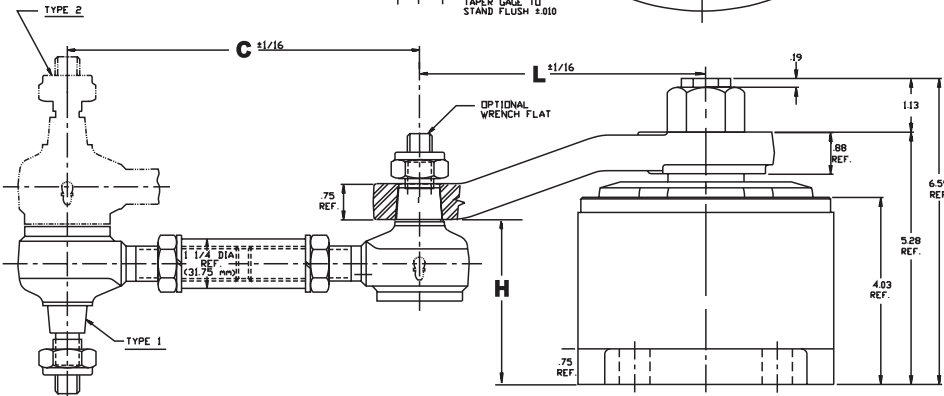

MOUNTING POSITIONS

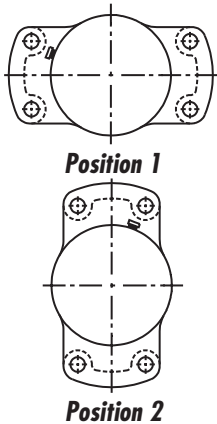

ROD END ASSEMBLY P/N 707832

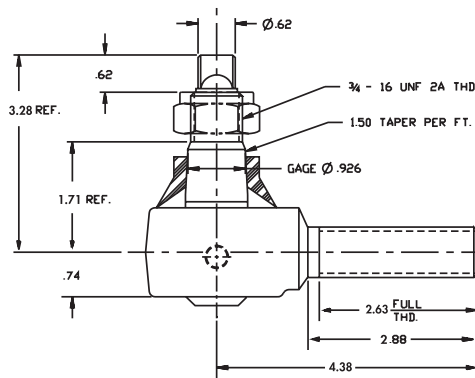

LEVER CONFIGURATIONS

